

A 20

# INSTRUCTIONS FOR THE USE AND CARE OF ZANUSSI MICROWAVE OVEN

INSTRUCTION BOOK DEPT.  
LIBRARY  
MASTER COPY

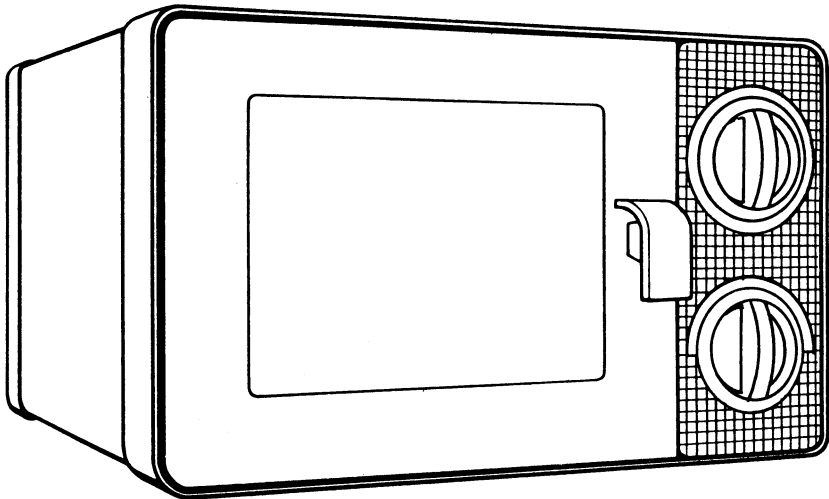

A20

Model No: MW 1132  
: MW 2132

**ZANUSSI**  
The appliance of science

**It is most important that this instruction book should be retained with the appliance for future reference. Should the appliance be sold or transferred to another owner, or should you move house and leave the appliance, always ensure that the book is supplied with the appliance in order that the new owner can be acquainted with the functioning of the appliance and the relevant warnings.**

## **Warnings – Microwaves**

**THESE WARNINGS ARE PROVIDED IN THE INTEREST OF SAFETY. YOU MUST READ THEM CAREFULLY BEFORE INSTALLING OR USING THE APPLIANCE.**

- This appliance is designed to be operated by adults. Children should not be allowed to tamper with the controls or play with the product.
  - Any electrical work required to install this appliance should be carried out by a qualified electrician.
  - This product should be serviced by an authorised Zanussi Network Service Centre, and only genuine Zanussi spare parts should be used.
  - It is dangerous to alter the specifications or modify the product in any way.
  - Do not overcook food. Overcooking certain food can result in dehydration and subsequently fire. Jacket potatoes and food with a high sugar content – such as those containing dried fruits – are particularly vulnerable. In case of fire unplug the oven and do not open the door.
  - Care and cleaning of the appliance are important. Food deposits should not be left on the interior cabinet. Do not place any object between the oven front face and the door, or allow the door seals to accumulate dirt.
  - Always be careful when removing protective film from food after cooking as the steam when released can cause burns.
  - Any foodstuffs with a «skin», e.g. potatoes, sausages etc, must be pierced before cooking in order to allow for the release of steam.
  - Under no circumstances should live animals be placed in a microwave.
  - Unplug the appliance if it is to be left for a period of time, e.g. during holidays or long weekends.
  - Bases of microwave browning dishes and similar cooking vessels get very hot. Care should be taken that the dish does not come into contact with any plastic surface. Wear protective gloves.
  - Please be cautious when eating food direct from the microwave as items with a high sugar or fat content can be very hot inside.
  - Only use cooking containers recommended for use in a microwave.
  - Do not use metal containers, metal glazed china, melamin or cut glass as cooking containers, or bags with metal ties.
  - Do not use more than the recommended quantities of aluminium foil in the oven.
  - Do not use capped bottles, jars or tins.
- Do not use the oven for drying any items.
- Leave the oven empty at all times when not in use and do not operate the oven when empty.
  - Do not let the timer continue to operate after removing the food.
  - Do not attempt to cook or reheat eggs in their shells, they may explode. Pierce egg yolks.
  - Do not attempt to deep fat fry in a microwave.
  - Do not operate the oven if it is damaged in any way. Under no circumstances should you attempt to repair the appliance yourself. Repairs carried out by inexperienced persons may cause serious injury. Consult your local Zanussi Network Service Centre. Always insist on genuine Zanussi spare parts.

# Contents

Page No.	4	Specifications
	5	Installation
	6	Features Diagram
	7	Getting to Know Your Oven
	8	Getting to Know Your Control Panel
	9	Using your Microwave Oven
		Operating the Oven
		The Variable Power Feature
	11	Shelf Cooking
	13	Safety Facts
	14	Microwave Cooking Terms and Techniques
	15	Cleaning and Maintenance
	16	Questions and Answers
	17	What Happens if Something Goes Wrong
	18	Zanussi Guarantee Conditions
	19	Zanussi 5 Year Cover

**Important:** the use of this new appliance is quite simple. However, to obtain the best results, it is recommended that you carefully read this handbook and follow all instructions prior to operating the appliance for the first time. This handbook provides all necessary instructions for a correct installation, use and care of the appliance and also gives a number of useful hints.

---

# Specifications

Power source:	240 volts A.C. 50Hz 3 wire grounded circuit
Power consumption:	1400 watts/input power 700 watts/output power
Oscillating frequency:	2450 MHz
Exterior dimensions:	Height: 35.2 cm Width: 55.8 cm Depth: 46.3 cm
Interior dimensions:	Height: 24.3 cm Width: 38.4 cm Depth: 38.4 cm
Oven capacity:	1.3 cubic ft
Weight:	24.7 kg

# Installation

## Positioning

This oven is free-standing and can be placed wherever you choose within reach of a power outlet. Ensure the surface is level and that the oven has adequate ventilation. There must be at least 2.5 cm/1 inch of clearance at the top, 4 cm/1½ inches at the back and a total of 15 cm/6 inches side clearance.

**NOTE:** Do not store cookbooks or this instruction book inside or underneath the oven.

## Electrical Connection

For your convenience and safety your new Zanussi microwave comes ready fitted with a moulded flex and plug. All you have to do is push the plug into a 13 amp power socket and switch on. However, if for some reason you need to replace this plug with one of your own, you will find the wires inside the flex are colour coded as follows:

GREEN AND YELLOW – EARTH  
BLUE – NEUTRAL  
BROWN – LIVE

If you fit your own plug, the colours of the wires in the mains lead of your appliance may not correspond with the markings identifying the terminals in your plug, this is what you have to do:

Connect the green and yellow (earth) wire to the terminal in the plug which is marked with the letter «E» or the earth symbol, or coloured green, or green and yellow.

Connect the blue (neutral wire) to the terminal in the plug which is marked with the letter «N» or coloured black. Connect the brown (live) wire to the terminal which is marked with the letter «L» or coloured red.

## Fuses

The appliance's moulded on plug is supplied fitted with a 13 amp BS1362 fuse. If this

fuse blows you can replace it in the following way:

– Remove the plug from the power socket and use a small screwdriver to lever out the red plastic fuse carrier located between the plug's prongs, together with the old fuse. Fit it with a new 13 amp fuse and clip it back into the plug. Make sure your new fuse is 'ASTA' approved. If the carrier is damaged you can get a new one from your local Zanussi Service Agent.

## Safety

The manufacturer declines to accept any liability should these safety measures not be observed;

- Check that the supply flex and any other wiring is positioned in such a way that when the microwave oven is operating its temperature at any point is less than 50 degrees C above the ambient temperature of the room.
- Never remove the rear panel of the oven to gain access to the terminal board. If an extension is required it should be made using the standardised plug and the external cable and it should be capable of carrying the expected load.
- Check that the fuse and domestic installation are suitable to carry the electric load of this appliance (see rating plate at the back of the oven).
- Check the appliance is properly earthed according to existing rules and regulations.
- The appliance meets the requirements laid down in EEC Directive No. 76/889 and amendment 82/499 relating to the suppression of radio and TV interference.

**IMPORTANT: UNDER NO CIRCUMSTANCES SHOULD ANY SERVICE REPAIR WORK BE CARRIED OUT ON THIS APPLIANCE BY UNQUALIFIED PERSONS.**

# Features

- A: Control Panel
- B: Sealed-in Oven Floor
- C: Safety Interlock System
- D: Door Handle
- E: Door
- F: Stirrer Cover
- G: Light
- H: Metal Oven Shelf

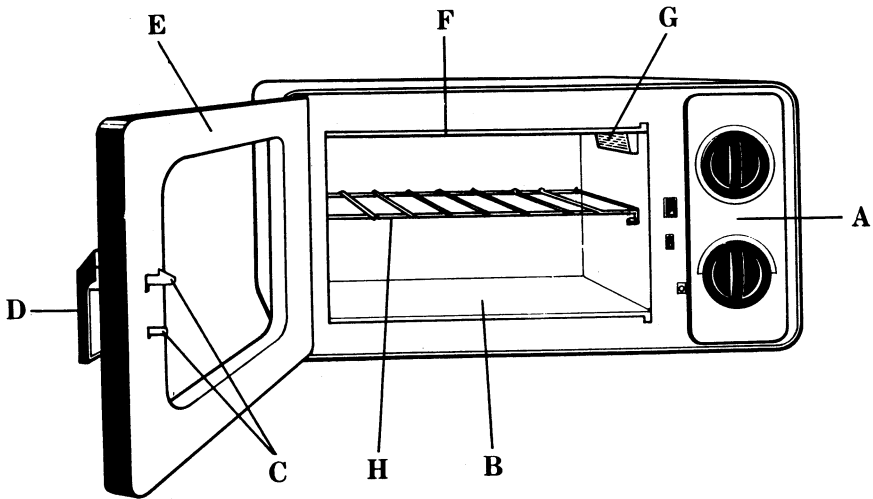

---

# Getting to Know Your Oven

- A: Control Panel
- B: Sealed-in Oven Floor
- C: Safety Interlock System
- D: Door Handle
- E: Door
- F: Stirrer Cover
- G: Light
- H: Metal Oven Shelf

## **A – Control Panel**

This controls the programming of the microwave oven. (See detailed description under 'Getting to Know Your Control Panel').

## **B – Sealed-in Oven Floor**

This sealed-in oven floor allows the food to be penetrated from the base upwards. The microwaves pass through the oven floor and bounce off the metal base back into the oven cavity.

The oven floor is sealed-in for easy cleaning.

## **C – Safety Interlock System**

This ensures that the oven cannot operate with the door open. The oven automatically switches off when the door is opened.

## **D – Door Handle**

Lift the handle from the bottom to open the door. As the door opens the interior light comes on. To close the door, just push it back into place until you hear a click.

## **E – Oven Door**

The door has two skins sandwiching a metal mesh. This mesh deflects the microwaves back into the oven cavity. The door has also been designed to give clear vision to the inside of the oven.

## **F – Stirrer Cover**

This plastic cover protects the stirrer from a build up of soil. The blade is designed to distribute the microwaves evenly throughout the oven cavity. The stirrer cover should not be removed.

## **G – Light**

The light operates when the oven is in use or the door is opened. It switches off at the same time as the programme finishes.

## **H – Metal Oven Shelf**

Used when cooking complete meals, or when using more than one dish in the oven. Shelf should be removed when not being used.

# Getting to Know Your Control Panel

## 1 – Time Control Knob

A 60 minute control timer. Turn the knob clockwise to set cooking time. To decrease time if required, turn the knob anti-clockwise.

## 2 – Variable Power Control Knob

Use to set desired power level. This enables you to have total flexibility when selecting the microwave speed suitable for the food that is being cooked.

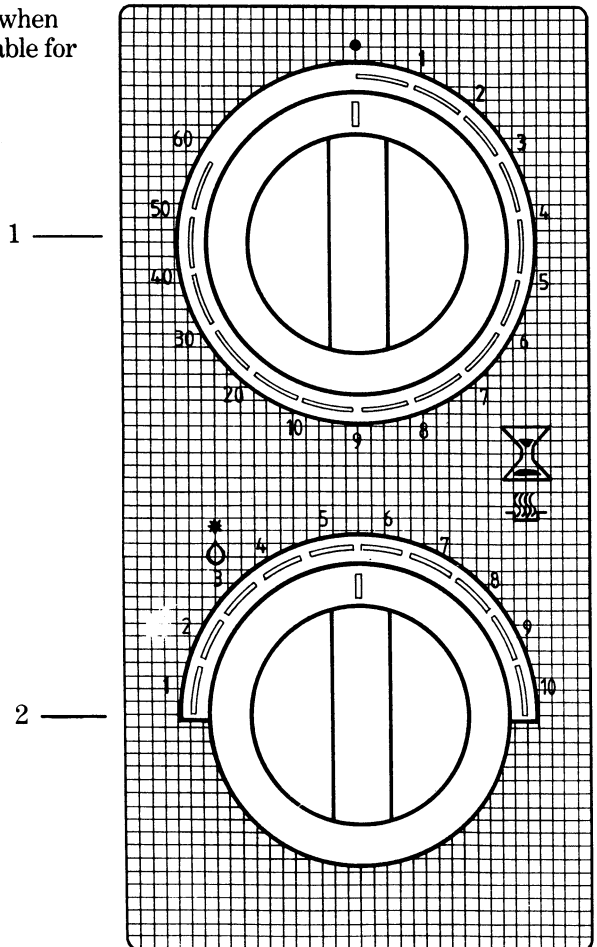



---

# Using Your Microwave Oven

## The Microwave Oven

Microwave cooking is very versatile. It enables you to cook, reheat, roast, simmer, hold-warm and even defrost with speed and convenience.

As microwaving is such a new and fast way of cooking, you must be prepared to gradually become more adventurous as you progress.

Start with something easy; heat a cup of coffee in a mug for two minutes, but open the door at any time and check if the coffee is as hot as you like it. Next try heating leftovers on a plate. An average serving takes about 2-3 minutes on power level 8. Look for steam or test the food to see if it is ready.

Feel free to open the door at any time. If additional time is needed, add it gradually. It is better to under estimate than over estimate.

Before using the microwave oven for the first time, be sure all the packaging materials from both the outside and inside of the oven have been removed. Wipe out the inside of the oven with a damp cloth.

Each recipe in the cookbook gives the approximate cooking time. This is because many factors such as food temperature, dish shape, arrangement of food and density control the precise time.

Start with a shorter time and add time if needed.

Remember the cookbook is only a guide.

## Operating the Oven

1. Pull up the door handle. The interior light will come on automatically when the door opens.
2. Place the food item inside the oven.
3. Set the appropriate power level by turning knob 2 until the desired power level is reached.
4. Set the timer for the desired time by turning knob 1 clockwise.
5. Close the door. The oven will start cooking. The door may be opened at any point to check food, even if there is time left on the dial. The timer will maintain the time setting and cooking will continue when door is reclosed.
6. When the time is up, a bell rings once and the oven turns off automatically.

## Variable Power Feature

There are ten power settings which allow total flexibility in choosing the speed of microwave cooking. This enables you to get the best cooking results for each type of food, just as you would use different temperature settings in conventional cooking.

The settings range from power level 10 which is 100% of power, to power level 1 which is 10% of power.

---

Basic uses are as follows:

<b>Power level</b>	<b>% Power</b>	<b>General uses</b>
1	10	Holding food warm.
2	20	Softening butter – raising bread.
3	30	Defrosting.
4	40	Warming syrups and sauces.
5	50	Slow cooking.
6	60	Heating frozen meal dishes e.g. fish pies, curries, casseroles.
7	70	Start cakes – cook soups and stews.
8	80	Reheat plated and leftover food.
9	90	Reheating larger items.
10	100	Full power for vegetables, fish, hot beverages, grill, preheating microwave browner.

---

# Shelf Cooking

## Using the Metal Shelf

The metal shelf enables you to microwave a number of dishes in approximately the same time.

### How to Insert the Shelf

1. Tip the shelf slightly, left side down and insert into the oven. Slide the shelf into the left supports.

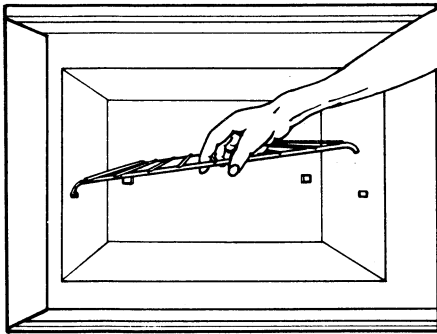

2. Lower the shelf onto the right side and back supports. Making sure the shelf is as far back as it will go, push down gently to secure in place.

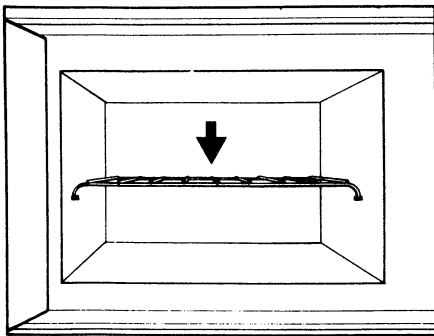

## Shelf Cooking

By using the metal shelf you are able to cook fast and slow cooking foods in approximately the same time.

Dense foods such as roasts, potatoes or casseroles should be placed on the metal shelf. Faster cooking foods such as frozen vegetables or beverages should be placed underneath.

As the microwaves enter the cavity at the top, whatever is placed on the metal shelf will receive the majority of the microwave energy. Therefore foods which are placed on the base will receive less microwave energy, thus enabling you to cook the food in approximately the same time. Very fast cooking food can be added later as you would when cooking conventionally.

It should be remembered that when more food is placed in the oven this will result in a longer cooking time.

### Tips on Shelf Cooking

- Stagger the food so that no food is directly above another.
- Check your meal while cooking. Stir if needed and add or remove food as required for the desired results.
- Turn or rotate dense food such as a roast.
- For the quickest cooking time 100% (High) power should be used. This is because the increase quantity of foods cuts the microwave energy available to each food.
- For foods which contain delicate ingredients such as cream and eggs and for less tender cuts of meat, you may

need to cook more slowly by lowering the power level, just as you would when cooking conventionally.

Listed are some typical foods which you might prepare as a main dish in a 'Meal-In-One'. Use the cooking times suggested as an approximate guide when making up your own 'Meal-In-One' ideas. The cooking times shown, take into consideration the fact that you will be cooking vegetables, desserts, etc., along with the main dish.

The Microwave cooking shelf should NOT be used in the same manner as a conventional cooking shelf.

It is only necessary to use the Microwave shelf where the number of items to be cooked exceed the space available in the base of the oven. We would also point out that items of food do not cook any quicker if placed on the shelf ie; in a higher position within the cavity. Never use the shelf if the base of the oven is not filled.

MEALS	MICROWAVE TIME RANGE	COMMENTS
Casserole Meals	12 to 35 mins.	Stir eggs $\frac{1}{4}$ way through. Add time for bacon if necessary
Chicken Meals	25 to 35 mins.	
Scrambled Eggs and Bacon	9 to 12 mins.	
Fish Meals	9 to 16 mins.	
Meatloaf/Meatball Meals	20 to 35 mins.	
Rib/Chop Meals	25 to 40 mins.	
Roast Meals	40 to 50 mins.	
Soup	4 to 7 mins.	
Steak Meals	8 to 12 mins, plus preheating time for microwave grill.	

# Safety Facts

To ensure maximum satisfaction from your microwave oven we would like to advise you of some precautions to observe when using your new microwave cooker.

- The microwave oven cooks much faster than conventional ovens. It is wise to take special care when you are cooking something for which specific timings have not been recommended. This applies particularly when reheating foods. Always watch the cooking or heating of the food in question, giving it short cooking times and adding more until you have obtained the desired result. You will soon learn the correct timings for cooking or heating your favourite foods. It is important to remember that it is possible to burn foods if they are cooked for too long, but the burning will occur inside the food first and will only become apparent by smell.
  - Unlike conventional cooking microwaves do not radiate heat, they generate it within the food. Therefore, the container should only become hot where it is in contact with the food.
  - **Do Not** attempt to operate the oven with the door open by tampering with the safety interlocks.
  - **Do Not** place any object between the oven front face and the door or allow the sealing surfaces to accumulate dirt.
  - **Do Not** use metal cookware in the oven.
  - **CARE SHOULD BE TAKEN WHEN REHEATING ITEMS WITH A HIGH SUGAR OR FAT CONTENT.**
- When reheating small items such as mince pies, take care to under estimate reheating times rather than over estimate.
- Example: 2 mince pies on power level 8 take 20-30 seconds only.
- **Do Not** use the oven for storage when it is not in use.
  - **Do Not** attempt to run the oven with no food in it.
  - **Do Not** let the timer continue to operate after removing food.
  - **Do Not** attempt to cook or reheat eggs in the shell in the microwave oven: They may explode.
  - **Do Not** operate the oven if it is damaged in any way.

---

# Microwave Cooking Terms and Techniques

## **Stirring**

With foods such as casseroles, sauces and soups it is necessary to stir the ingredients during the cooking time so the heat is evenly distributed.

## **Arrangement of Food**

To ensure even cooking of food it is best to arrange it so the thinner parts are towards the centre of the dish and the thicker more dense parts are on the outside. For example, if cooking chicken drumsticks the narrow end would be in the centre of the dish, and the thicker end would be pointing to the outer edge.

## **Turning Food**

Again to ensure even cooking of food, dense items such as hams, roasts or whole poultry should be turned at least once during the cooking programme. When using individual dishes it is advisable at some time during the cooking programme to re-arrange the dishes, so they will all be ready at the same time.

## **Standing Time**

Microwaves penetrate food only to a depth of 4 cm/1½ inches, so the dense food items are best left to stand for a short period of time once the microwave cooking is complete. This ensures the heat inside the food will penetrate to the centre and ensure it is completely cooked. Standing time can take place either on the kitchen surface or in the microwave with the power off. The food is covered, often with foil, and left so the heat can transfer evenly throughout the food. The denser the food the longer the standing time.

## **Shape of Food**

Always aim for uniform shapes to aid the even cooking of food. This is especially relevant when cooking joints of meat and it is advisable to bone and roll joints such as legs of lamb before cooking.

## **Covering**

There are several types of covering and they are all used for different purposes. Plastic film or glass lids help to hold in steam and therefore retain moisture so the food can cook more quickly. Paper towels or napkins are loose covers used to prevent spitting and also to absorb moisture. Wax paper is also a loose cover which holds in some of the moisture and therefore speeds up the cooking time.

## **Cookware**

The range of cooking utensils that can be used in the microwave is wide. There are many excellent varieties of cookware specially manufactured for use in the microwave/freezer, also much of the conventional kitchen equipment is quite suitable. The basic rule to remember is not to use anything made of metal or with any metal parts and that includes screws, handles, metallic designs on plates, foil dishes, even metal ties on foods from the freezer. Also avoid some plastics such as melamine or urethane, the microwave may warp or crack them. The most suitable dishes are made of china or pottery, ovenproof glass or paper. For further information see your microwave cook book.

# Cleaning and Maintenance

## Microwave Oven cleaning

Your microwave oven requires a minimum of maintenance. To keep it free from grease and soil build-up, the microwave oven should be cleaned with a damp cloth after each use. A soft nail brush can be used to remove stubborn stains. Odours can be eliminated from the inside of the oven by boiling a solution of one cup of water and several tablespoons of lemon juice in the cavity. This also helps in loosening soil which has dried on the oven. We would also recommend occasionally wiping the oven interior with a sterilising fluid, i.e. Milton, in the interest of hygiene.

Use only a mild detergent, water and a soft clean cloth to clean the oven face and all surfaces. Be careful not to scratch the door and interior surface. Wipe out excess moisture after each use.

**DO NOT USE:** Abrasive cleaners, cleaning pads or steel wool.

Be sure the oven is cleaned carefully after every use.

## Replacement of Interior Light

The oven interior light is easily replaced. First unplug the oven. Turn the cooker round and unsnap and remove the 'Lamp Access Cover' on the back of the oven. In some models a screw must first be removed to release the cover. Replace the bulb with a 15-watt (E14) available from hardware stores or the local Zanussi Service Centre.

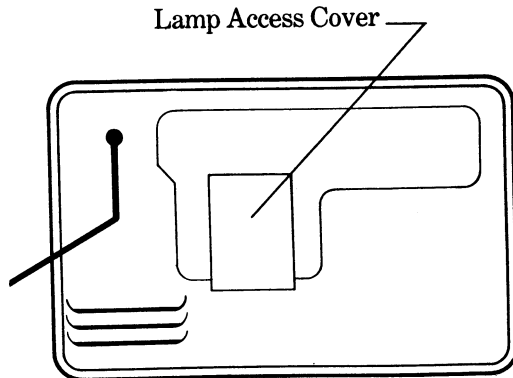

---

# Questions and Answers

**Q** What happens if I accidentally operate the microwave oven with no food in it?

**A** While such accidental use of short periods of time does not damage the magnetron, it is not recommended.

**Q** Is eating food cooked in a microwave oven harmful?

**A** Microwaves are simply a source of heat energy just like gas and electricity. All three produce cooking in the food itself. Food cooked in a microwave oven is not harmful to eat.

**Q** Why do I have moisture in the microwave oven after cooking?

**A** The moisture on the inside of your microwave oven is normal and nothing to worry about. It is caused by the steam from the cooking food hitting a cool oven surface. Wipe excess moisture from the inside of the oven after each use.

**Q** What causes the oven interior light to dim when using Variable Power?

**A** This is normal and indicates that the oven is operating and cycling normally.

**Q** Foods cooked in a microwave oven seem to cool off faster than conventionally cooked foods. Why is that?

**A** Often the dish used to store foods in the refrigerator is used for heating in the microwave oven. In this case, the cold dish absorbs heat from the food. It may be necessary to heat the food for additional time.



---

# What Happens if Something Goes Wrong

## **Important**

If the oven does not come on:

- check that the appliance is connected correctly;
- check that the switch from the supply to the appliance is ON;
- replace the fuse in the socket, where present, with another of the appropriate rating;
- check that the fuse in the fuse box is intact.
- If after all these checks the appliance still does not work, call your local Zanussi Network Service Centre listed in the telephone directory. It helps to jot down the address and telephone number in the space below.

**Never attempt to remove the rear panel of the oven or tamper with the oven in any way.**

**IMPORTANT: UNDER NO CIRCUMSTANCES SHOULD ANY SERVICE REPAIR WORK BE CARRIED OUT ON THIS APPLIANCE BY UNQUALIFIED PERSONS.**

---

# Peace of mind for twelve months

## ZANUSSI STANDARD GUARANTEE CONDITIONS

This guarantee is in addition to your statutory and other legal rights which will not be excluded or in any way diminished by the return of this guarantee card.

We, IAZ International (UK) Ltd, undertake that if, within twelve months of the date of the purchase, this ZANUSSI appliance or any part thereof is proved to be defective by reason only of faulty workmanship or materials, we will, at our option, repair or replace the same **FREE OF ANY CHARGE** for labour, materials or carriage on condition that:

- The appliance has been correctly installed and used only on the electricity supply stated on the rating plate.
- The appliance has been used for normal domestic purposes only, and in accordance with the manufacturer's operating and maintenance instructions.
- The appliance has not been serviced, maintained, repaired, taken apart or tampered with by any person not authorised by us.
- The appliance is still in the possession of the original purchaser.

All service work under this guarantee must be undertaken by a Zanussi Network Service Centre.

Any appliance or defective part replaced shall become our property.

### Exclusions

This guarantee does not cover:

- Damage or calls resulting from transportation, improper use or neglect, the replacement of any light bulbs or removable parts of glass or plastic.
- Cost incurred for calls to put right machines improperly installed or calls to machines outside the UK and the Republic of Ireland.
- Appliances found to be in use within a commercial environment, plus those which are the subject of rental agreements.

---

# or five years

## ZANUSSI 5 YEAR COVER CONDITIONS (See enclosed leaflet)

For a once-only payment you can extend your Standard Guarantee, all the conditions and exclusions of which apply.

1. Products supplied as 'seconds', refurbished, damaged or shop-soiled are not eligible for Zanussi cover.
2. The issue of a cover does NOT by virtue of our having done so, nullify the exclusions.
3. The Engineer will need to check the details of your Cover card and will make a charge for his services if it is not presented to him at the time of his call.
4. The date of purchase, or the date of initial payment (deposit) of the appliance will be deemed the date of commencement of cover.
5. Covers issued are not refundable or transferable.
6. Change of address:

Zanussi Cover Card is valid throughout UK, including Isle of Man, Channel Islands, Northern Ireland and Republic of Ireland and does not require amending. Advice in writing, quoting the 'Cover' Card number is necessary to enable correction of our records.

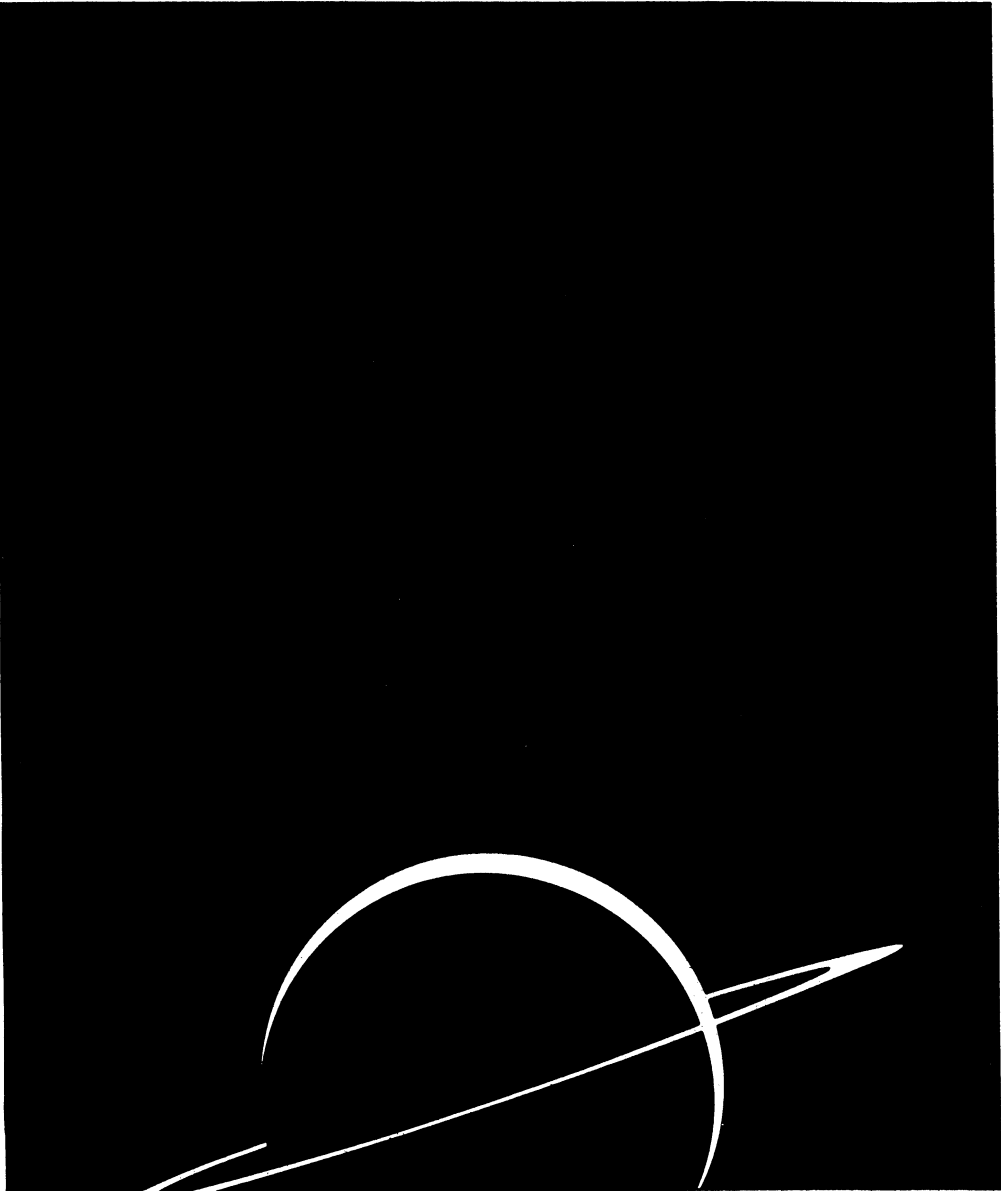

# ZANUSSI

The appliance of science

Zanussi Ltd., Hambridge Road, Newbury.

The information in this manual is correct at time of going to press.  
Zanussi reserve the right to alter specifications without notice.